

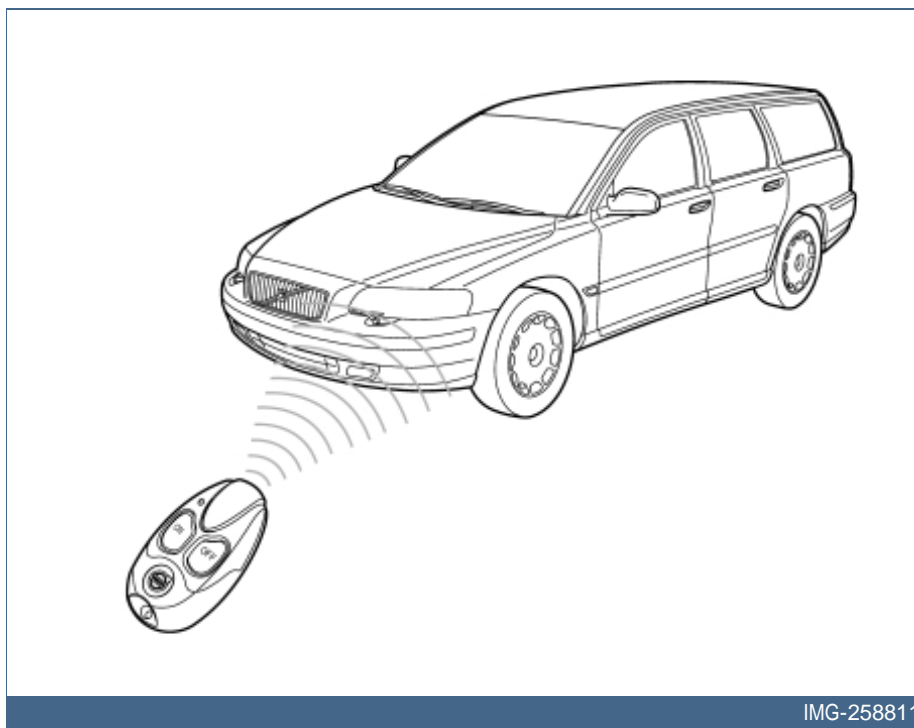

S60 / S80 / V70 / V70 XC / XC70 / XC90

Section	Group	Weight(Kg/Pounds)	Year	Month
8	875	0.5/1.1	2006	10



IMG-258811



## Required tools

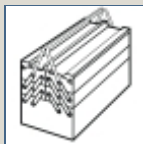

A0000162



IMG-239667



IMG-242205

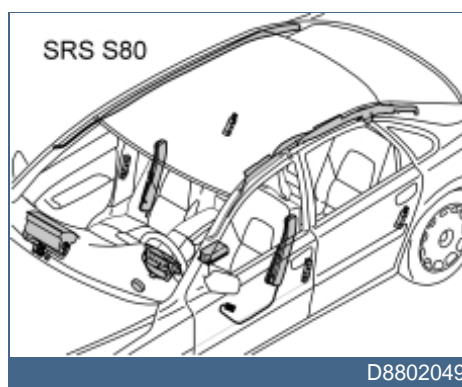
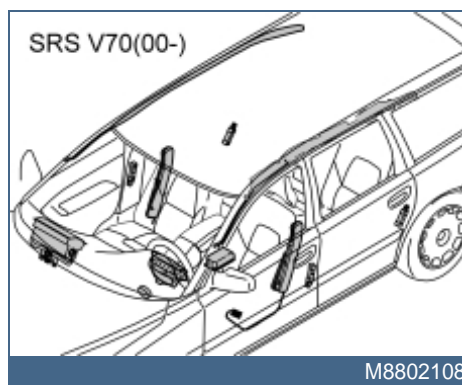
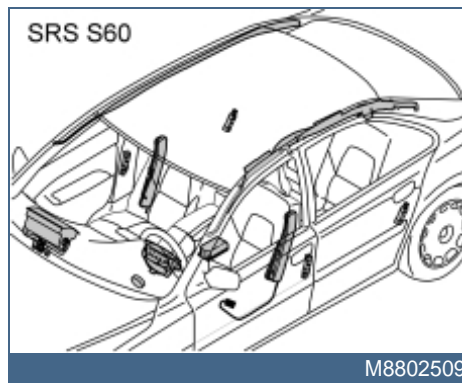

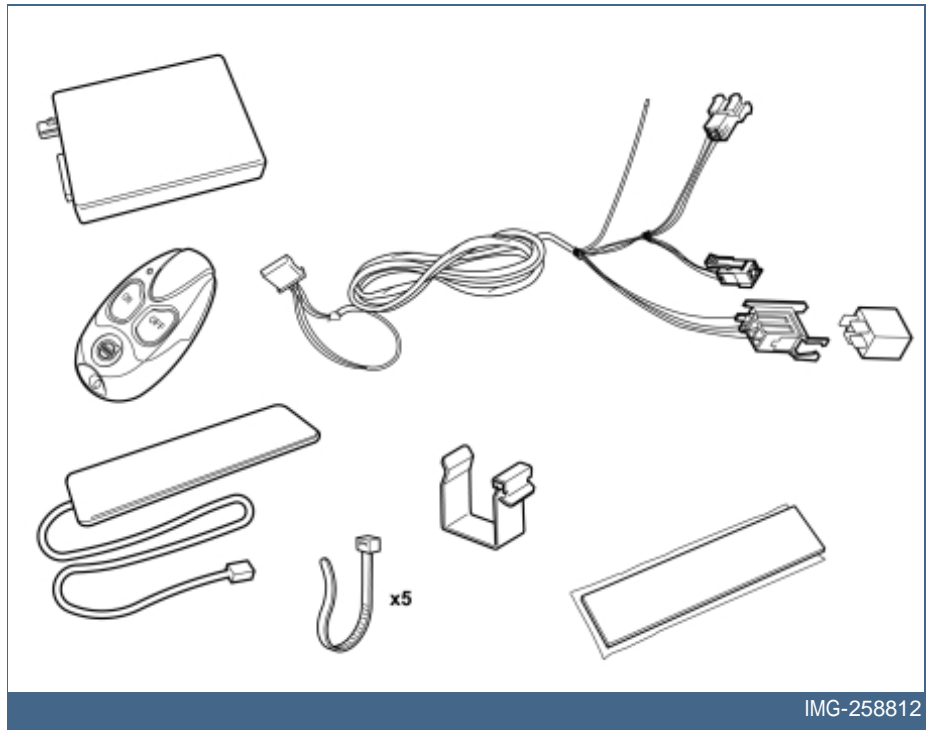



Any comments on this publication? Please contact your nearest retailer. Thank You!

Publ.no:	Issue:	Kit no:
Comments:.....		
.....		
.....		
.....		

From:	
Address:	
Telephone:	
Telefax:	

IMG-213320



## INTRODUCTION

- **NOTE! Read through the entire text before carrying out any work.**
- The front page gives the date of this edition and the edition it replaces
- The second page shows the tools needed for the installation and the contents of the installation kit
- The illustrations display the procedure in order of operation. The order of operation is repeated in the text section
- Cut out the text page in order to follow the illustrations and text at the same time.

## Cars equipped with SRS/SIPS (Airbag)

### Warning!

Extra care must be taken when working on cars equipped with SRS/SIPS air bags. This is important to prevent:

1. Personal injury
2. Damage to or malfunction of the SRS/SIPS system.

Work on the SRS/SIPS systems or related components must always be carried out by an authorised Volvo workshop.

## Is the car equipped with SRS (supplemental restraint system)?

Cars equipped with a driver's airbag have the letters "SRS" imprinted on the centre panel of the steering wheel. Cars equipped with driver's and passenger airbags are marked with "SRS" on both the steering wheel centre panel and also on the dashboard close to the airbag.

If the car is equipped with SIPS (side impact protection system ) a "SIPS" decal is marked on both the front seats.

Cars equipped with inflatable curtains have the marking "SRS" on one of the panels along the posts on the inside of the car.

Cars equipped with SRS (supplemental restraint system) also have a "SRS" decal on the front windscreen.

### Do not damage the SRS wiring!

Do not trap, fray, pierce or damage the SRS wiring. SRS wiring has orange casing and/or is plaited.

### Steering and front suspension

The contact reel in the SRS system can easily be damaged when working on the steering wheel, steering shaft or steering gear. Refer to the SRS (supplemental restraint system) Service Manual or service instructions in VIDA for information on carrying out such work. This is to prevent damage.

### SRS warning lamp

If the SRS warning lamp lights after repairs have been carried out, take the car to an authorised Volvo workshop.

### SRS collision sensor control module

#### S60 / V70 (00-) / S80 / XC90

The collision sensor control module is located on the transmission tunnel



in the centre console, in front of the parking brake.

**WARNING!**

**The air bag inflation areas must not be obstructed. Never place any objects, such as upholstery or accessories, within these areas. The panels must be able to deploy in the correct manner at the right time otherwise there is a risk of personal injury in the event of a collision.**

**WARNING!**

**The ignition must be in position "0" and the key removed from the ignition if any connector in the SRS system is to be disassembled. Then wait at least one minute. Then disconnect the battery negative lead before disassembling any of the connectors. When work is completed the ignition key must be turned to position "II" before reconnecting the battery negative lead.**

**Remote start, fuel-driven heater**

**Note!**

This accessory requires software unique to the car.



1

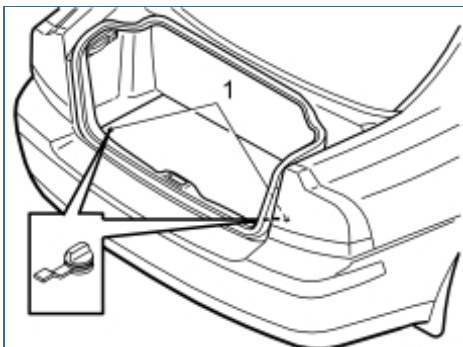

M8503480

Steps 1–32 apply to the S60/S80

**Applies to the S60**

- Remove the cargo compartment carpet at the rear edge. First turn the two handles (1) 90°.

2

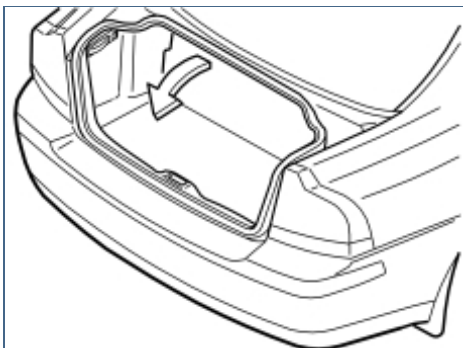

M8503481

Steps 1–32 apply to the S60/S80

**Applies to the S60**

- Pull up the front of the cargo compartment carpet. Fold the front half back over the rear half of the cargo compartment carpet.

3

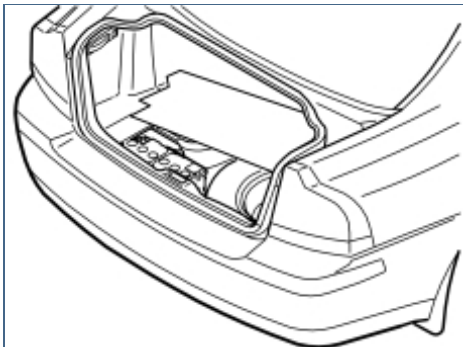

M8503482

Steps 1–32 apply to the S60/S80

**Applies to the S60**

- Slide the entire cargo compartment carpet forward slightly. Twist slightly to remove the carpet through the tailgate opening.

**Applies to the S80**

- Fold the cargo compartment carpet together. Twist the cargo compartment carpet slightly so that it can be removed from the cargo compartment.

**Applies to S60/S80**

- Remove the carpet from the luggage compartment.

4

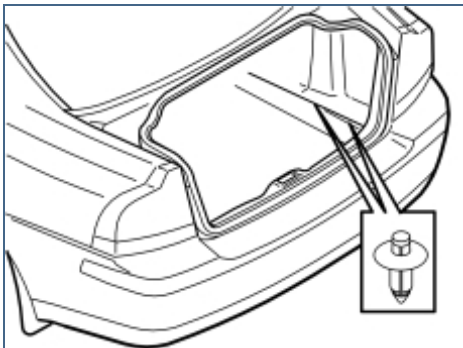

M8503478

Steps 1–32 apply to the S60/S80

- Press the center of the clip into the lower edge of the folding side panel on the right-hand left-hand side until a click is heard.
- Remove the clips.



5

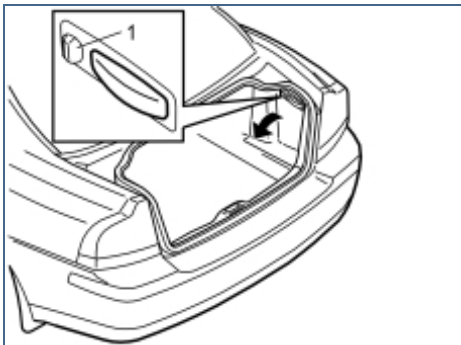

M8503479

**Steps 1–32 apply to the S60/S80**

- Turn the handle (1) on the right-hand side through 90°.
- Fold the side panel inwards and lift it out.

6

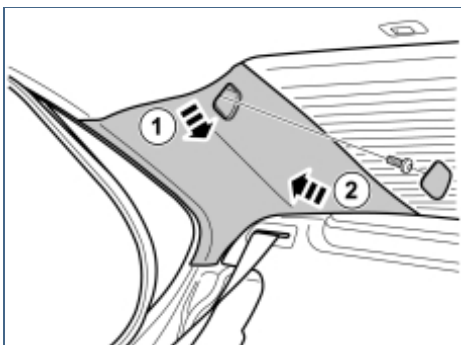

IMG-258823

**Steps 1–32 apply to the S60/S80**

**Applies to the S60**

- Remove the weatherstrip by the C pillar panel at the rear edge of the rear door opening.
- Remove cover and screw from the top of the panel.
- Pull the top edge of the C pillar panel inwards into the car (1). Fold the panel forwards (2) and lift it out.

7

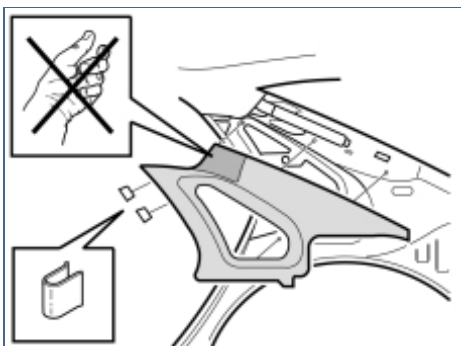

IMG-258824

**Steps 1–32 apply to the S60/S80**

**Applies to the S80**

- Remove the weatherstrip by the C pillar panel at the rear edge of the rear door opening.
- Remove the two steel clips at the front edge/upper edge of the panel.
- Pull the top edge of the C pillar panel inwards into the car. Fold the panel forwards and lift it out.

**Note!**

When removing the C pillar panel, do not grip it with your hand or with a tool in the area around the IC hatch (1), as the joint function in the hatch would then become deformed and it cannot be reset.





8

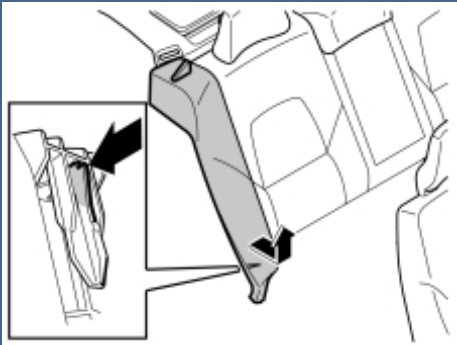

IMG-258825

Steps 1–32 apply to the S60/S80

**Applies to the S80**

- Unthread the belt from the belt guide.
- Insert a hand down the side of the lower section of the side cushion. Release the catches while lifting the side cushion.

9

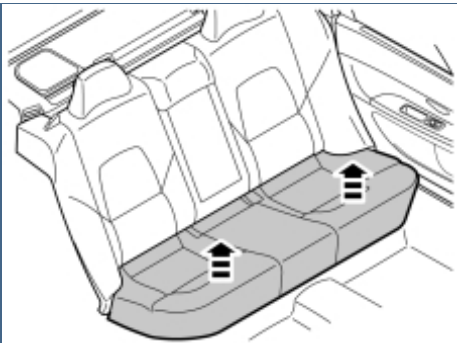

IMG-258826

Steps 1–32 apply to the S60/S80

**Applies to the S80**

- First lift the bottom edge of the short end of the cushion and then the front edge and pull it off.

**Note!**

The cushion may be securely attached.

- Lift out the cushion.
- Check that all the clips are intact. If not, they must be replaced.

10

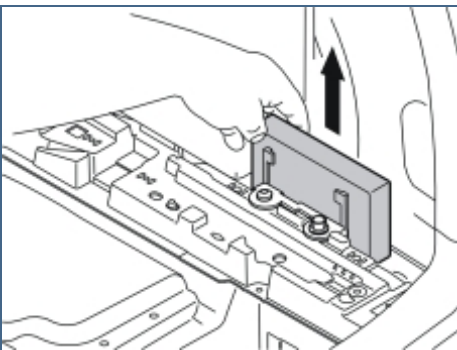

M3702528

**Applies to S60/S80**

- Lift the accessory electronic module (AEM) out of the bracket.

11

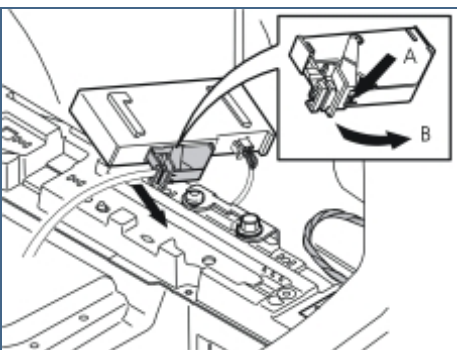

M3702529

- Disconnect the large connector from the accessory electronic module (AEM) by pressing in the catch (A) and pulling the black handle (B) in the direction of the arrows until a click is heard.
- Disconnect the connector from the accessory electronic module (AEM).



12

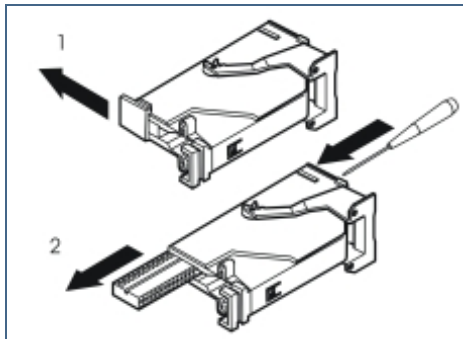

M3702530

**Remove:**

- the black catch (1) holding the black switch in place in the connector by pulling in the direction of the arrow.
- the black switch (2) by inserting a pointed object in the hole in the other end. Press out.

13

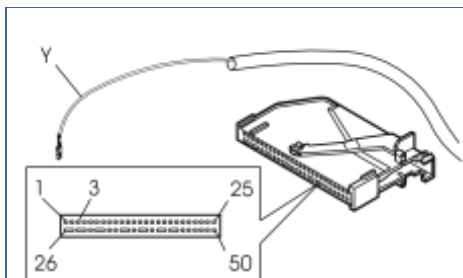

M3702955

- Connect the yellow cable from the control module to terminal 3 in the accessory electronic module (AEM) connector.

**Note!**

The numerical markings on the top and bottom of the black terminal pin are extremely small, so be careful when installing the cable.

**Reinstall:**

- the black switch in the connector. Lock it into place using the catch.
- the connector into the accessory electronic module (AEM). Secure using the black locking handle.

14

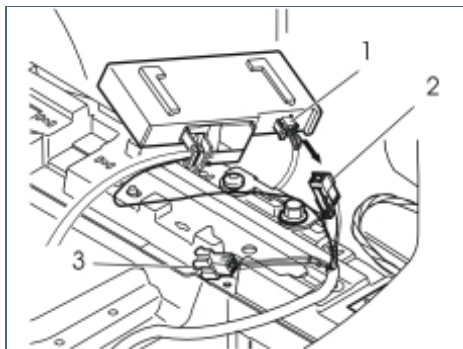

M3702956

- Remove the connector (1) from the accessory electronic module (AEM).
- Connect the corresponding connector (2) to the T-cable for the thick cable harness, for the accessory electronic module (AEM).
- Connect the remaining connector (3) on the T-cable to the connector that was disconnected from the accessory electronic module (AEM).
- Reinstall the accessory electronic module (AEM) in its bracket.

15

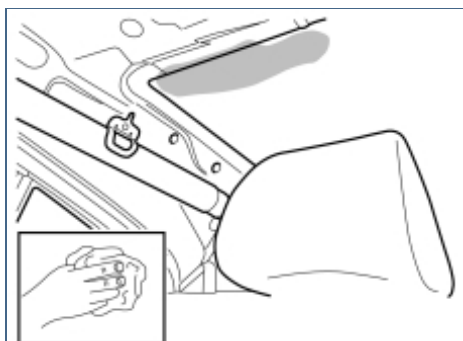

IMG-258827

- Clean the marked surface on the inside of the rear window below the panel edge using isopropanol, **part no. 1161721**, and wipe dry.



16

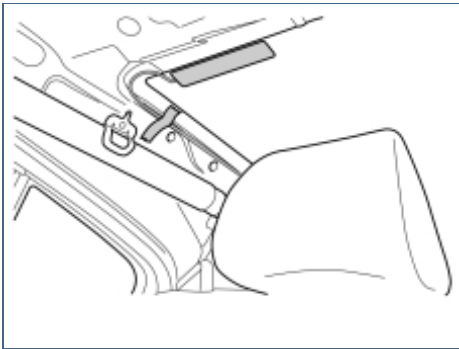

IMG-258828

- Press the antenna onto the inside of the window, as close to the panel edge as possible.
- Tape the cable securely in place.

17

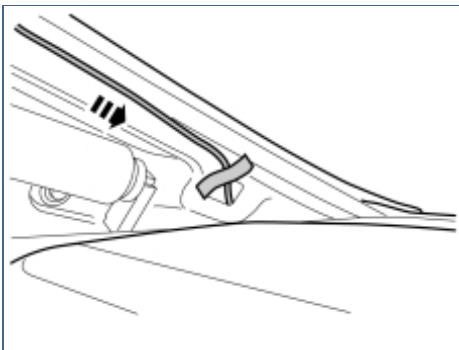

IMG-258829

- Pull the antenna cable through the hole for the panel's guide.
- Tape the cable harness at the panel to protect it against wear from the panel's guide.

18

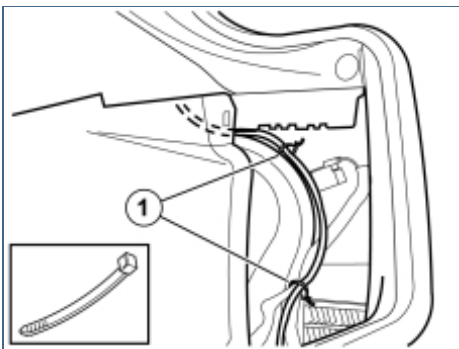

IMG-258831

- Secure the antenna cable (1) as illustrated.

19

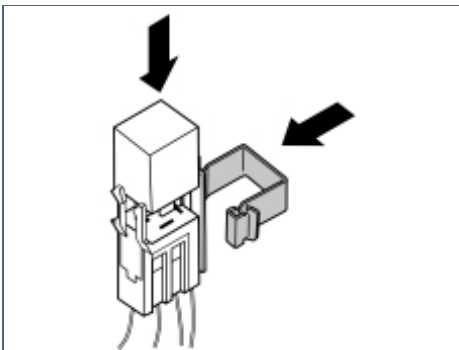

M8703702

- Take the relay and the large clip from the kit.
- Press the relay into the relay holder.
- Press the clip into the relay holder.



20

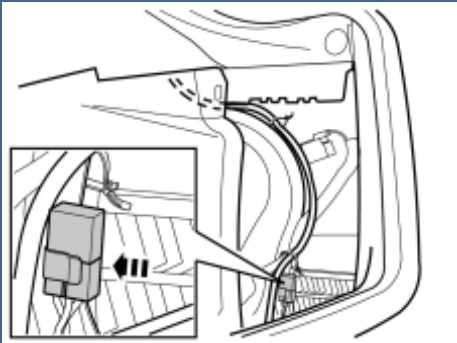

IMG-258832

- Press the clip with the relay holder and relay onto the panel edge at the rear edge of the wheel arch.

21

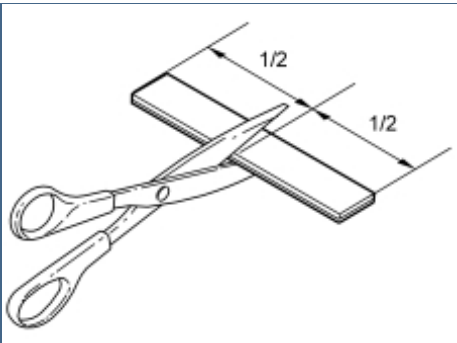

IMG-222282

- Remove the Velcro from the kit and cut it in the centre.

22

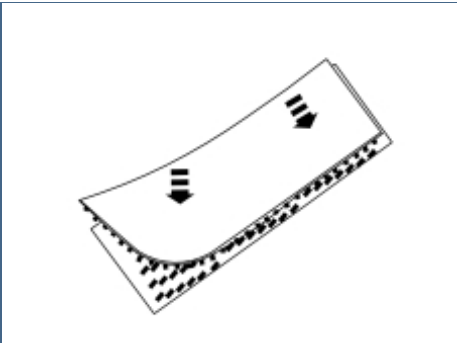

IMG-222283

- Press the Velcro pieces together.

23

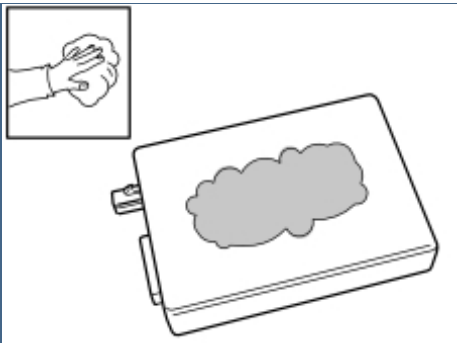

IMG-222284

- Wash the plane surface of the receiver unit using isopropanol **P/N 1161721** and wipe dry.



24

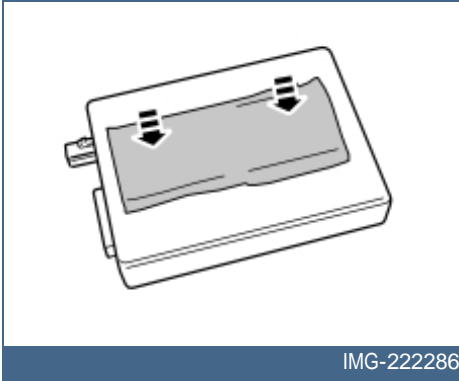

- Remove the backing from one side of the Velcro strips and press them onto the receiver unit.

25

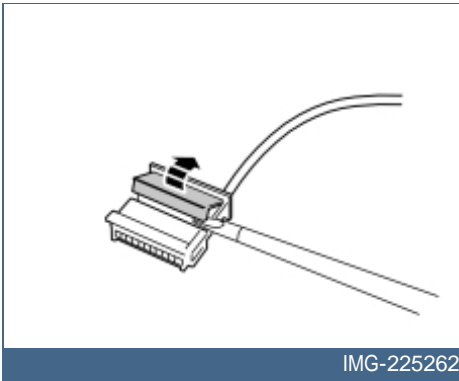

- Carefully loosen the secondary catch of the black six-pin connector from the kit using a small screwdriver.

26

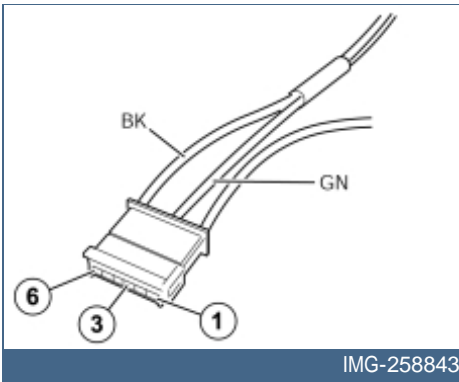

- Connect the green (GN) cable from the kit to terminal 3, and the black (BK) cable to terminal 6 in the six pin connector.
- Press the secondary catch into place on the black six pin connector.

27

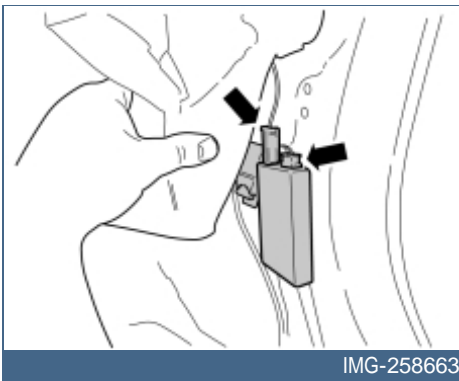

### Synchronizing the Transmitter - Receiver

- 1 - Connect the negative battery cable in the car.
- 2 - Put batteries in the transmitter battery compartment.
- 3 - Connect the connector and antenna cable to the receiver unit.
- 4 - Within 5 seconds, press the "OFF" button on the transmitter until the LED goes out. Synchronization complete.
- Press the receiver unit onto the Velcro on the body plate if it has loosened.

**Note!**



Tape up any cable excess from the timer relay and place next to the control module under the insulation.

28

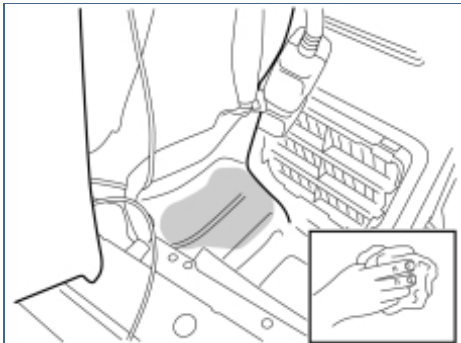

IMG-258846

- Clean the marked surface on the inside of the smooth panel surface using isopropanol, **part no. 1161721**, and wipe dry.

29

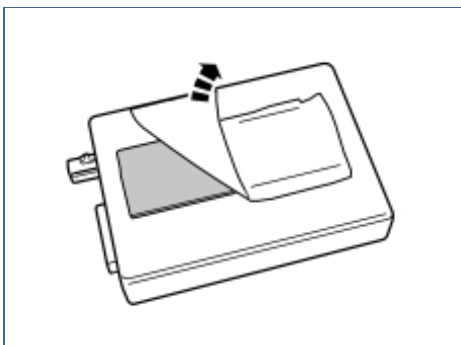

IMG-222287

- Remove the protective backing tape from the other Velcro piece.

30

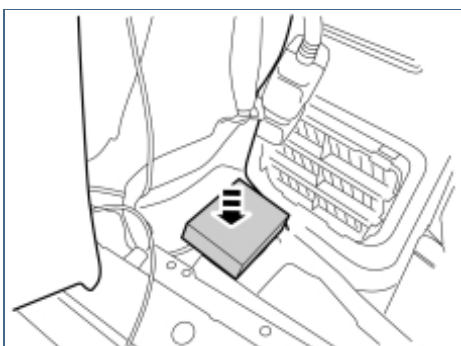

IMG-258864

- Press the receiver unit securely into place on the smooth surface.

31

- Reinstall the panels, mats, weatherstrips and seats according to the previous steps but in reverse order.



32

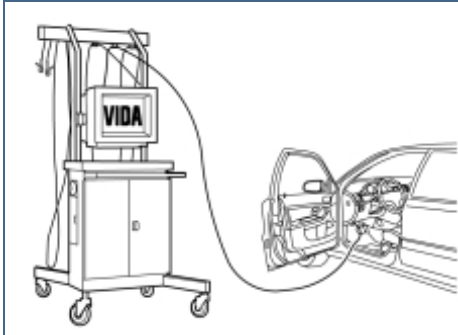

IMG-242268

- Programme the software in accordance with the service information in VIDA.
- Test the function according to the accessory manual.

33



M8502718

### Steps 33–54 apply to the V70

- Remove both the floor hatches. Lift the rear edges of the floor hatches slightly. Then pull the hatches backwards from their mountings.

34



M8503069

### Steps 33–54 apply to the V70

- Remove the right-hand folding panel in the cargo compartment.

35

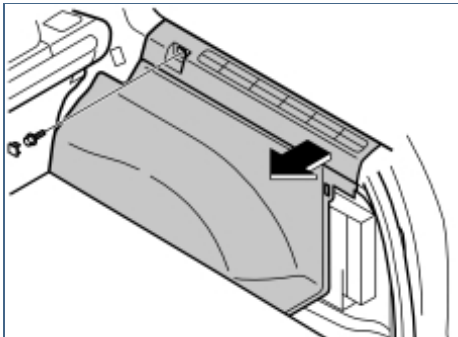

M8503008

### Steps 33–54 apply to the V70

- Remove the right side panel by first removing the cover and the screw in the front edge.
- Pull the top of the panel out until the clips release.
- Fold the panel inwards. Lift the panel out.



36

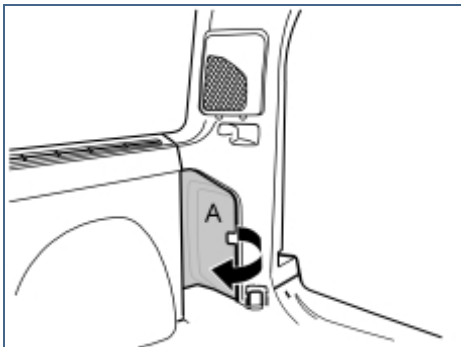

M8504252

## Steps 33–54 apply to the V70

- Remove the small insulation panel in front of the right-hand lamp by pulling it forward at point (A).

37

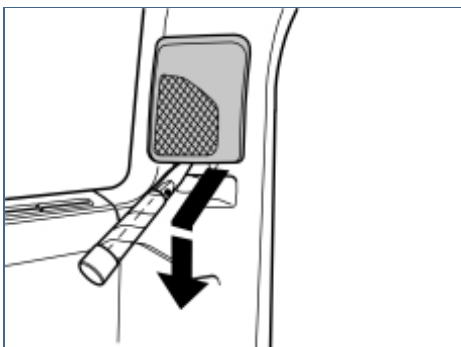

M8504269

## Steps 33–54 apply to the V70

- Remove the loudspeaker grille on the right-hand D pillar panel. First pry off the lower edge of the loudspeaker grille using a weatherstrip tool. Pull the grille out slightly and then downwards until the hooks at the top edge release.

38

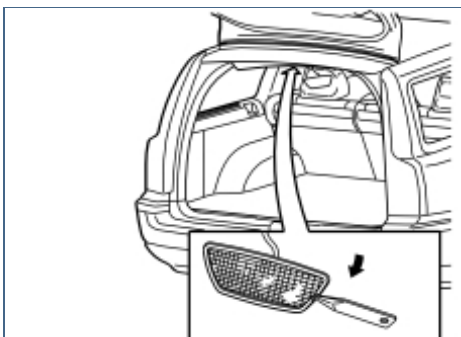

M8504271

## Steps 33–54 apply to the V70

- Carefully pry up the rear roof lighting using a weatherstrip tool.
- Unplug the connector from the roof lighting and move it aside.

39

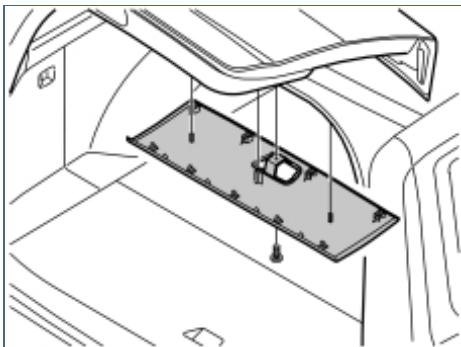

M8503005

## Steps 33–54 apply to the V70

- Remove the rear headlining panel by first removing the screw in the space where the roof lighting is. Pull off the front edge of the headlining to release the four clips. Then pull off the rear edge until the remaining clips release.





40

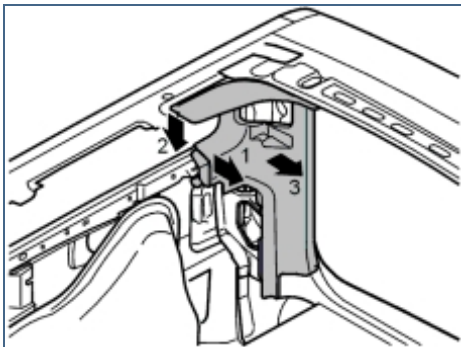

M8503010

Steps 33–54 apply to the V70

**Caution!**

Remove the panel in the following order otherwise the panel may become damaged.

- 1 - Grip the edge and pull inward so that the clips release.
- 2 - Detach the upper edge at the window so that the panel can pass the gas strut.
- 3 - Pull inward to make the clips in the opening release.
- 4 - Lift the panel upwards.

41

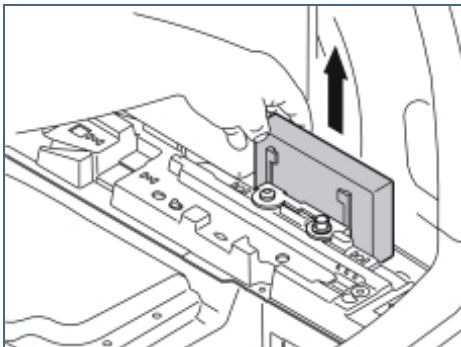

M3702528

Steps 33–54 apply to the V70

- Lift the accessory electronic module (AEM) out of the bracket.

42

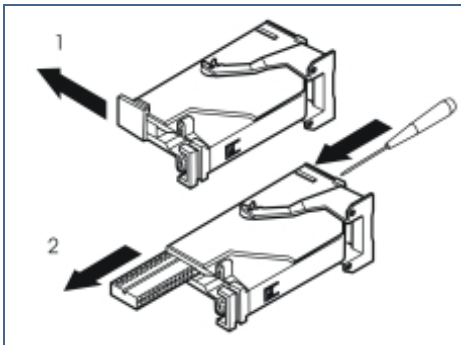

M3702530

Steps 33–54 apply to the V70

**Remove:**

- the black catch (1) holding the black switch in place in the connector by pulling in the direction of the arrow.
- the black switch (2) by inserting a pointed object in the hole in the other end. Press out.

43

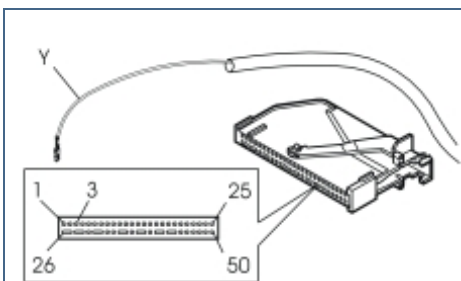

M3702955

Steps 33–54 apply to the V70

- Connect the yellow cable from the control module to terminal 3 in the accessory electronic module (AEM) connector.

**Note!**

The numerical markings on the top and bottom of the black terminal pin are extremely small, so be careful when installing the cable.

**Reinstall:**



- the black switch in the connector. Lock it into place using the catch.
- the connector into the accessory electronic module (AEM). Secure using the black locking handle.

44

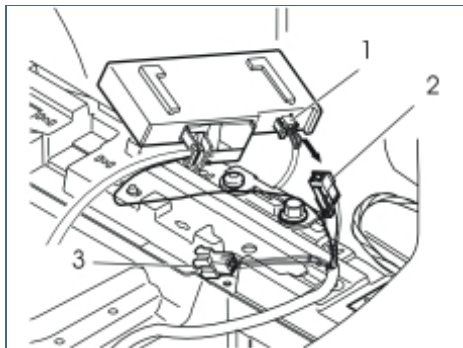

M3702956

### Steps 33–54 apply to the V70

- Remove the connector (1) from the accessory electronic module (AEM).
- Connect the corresponding connector (2) to the T-cable for the thick cable harness, for the accessory electronic module (AEM).
- Connect the remaining connector (3) on the T-cable to the connector that was disconnected from the accessory electronic module (AEM).
- Reinstall the accessory electronic module (AEM) in its bracket.

45

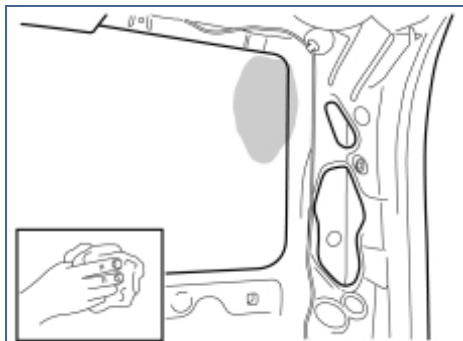

IMG-259205

### Steps 33–54 apply to the V70

- Clean the marked surface on the inside of the rear side window below the panel edge using isopropanol, **part no. 1161721**, and wipe dry.

46

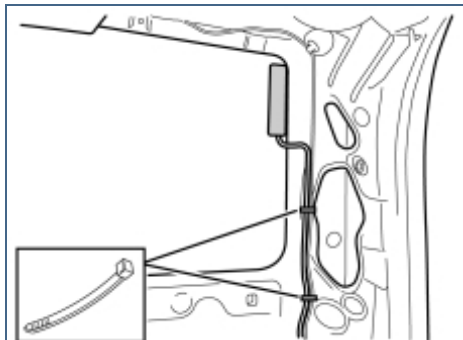

IMG-259206

### Steps 33–54 apply to the V70

- Press the antenna onto the inside of the window, as close to the panel edge as possible.
- Clamp the cable at the existing cable harness.



47

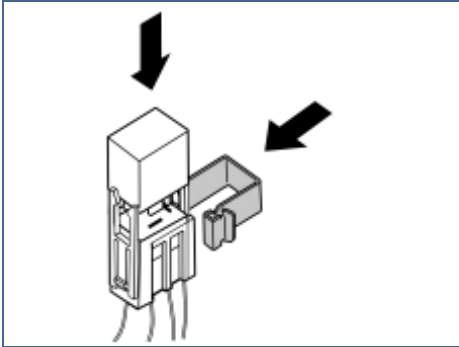

M8703709

## Steps 33–54 apply to the V70

- Take the relay and the large clip from the kit.
- Press the relay into the relay holder.
- Press the clip into the relay holder.

48

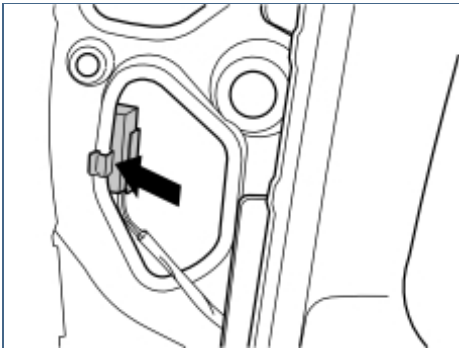

M8703710

## Steps 33–54 apply to the V70

- Press the clip with the relay holder and relay inside the panel edge in front of the right-hand rear lamp.

49

## Steps 33–54 apply to the V70

- Carry out steps 21-27.

50

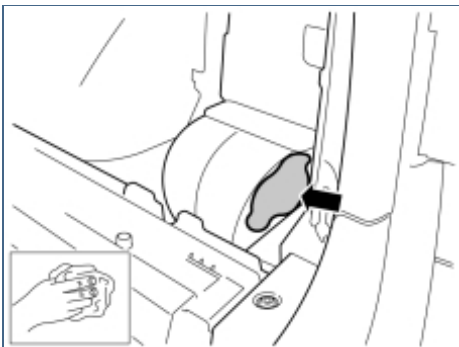

IMG-259643

## Steps 33–54 apply to the V70

- Clean the marked surface on the rear end of the right-hand vent. Use isopropanol, **part no. 1161721**, and wipe dry.

51

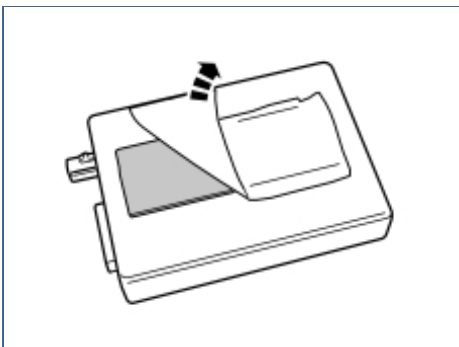

IMG-222287

## Steps 33–54 apply to the V70

- Remove the protective backing tape from the other Velcro piece.



52

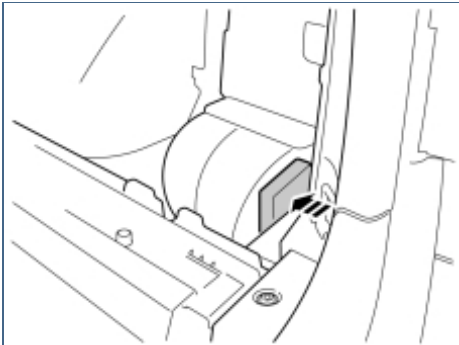

IMG-259227

## Steps 33–54 apply to the V70

- Press the receiver unit securely into place on the rear end of the right-hand vent.

53

## Steps 33–54 apply to the V70

- Reinstall the panels, mats, and covers according to the previous steps but in reverse order.

54

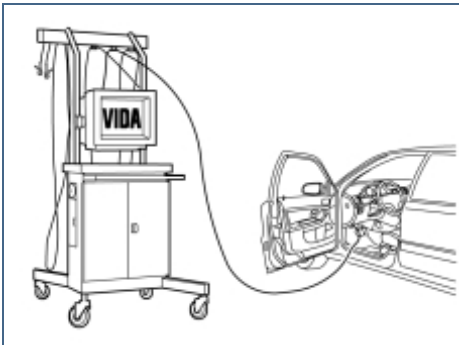

IMG-242268

## Steps 33–54 apply to the V70

- Programme the software in accordance with the service information in VIDA.
- Test the function according to the accessory manual.

55

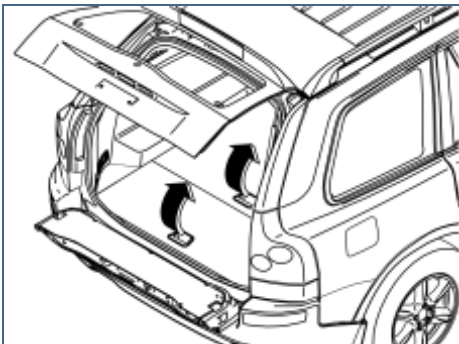

R8902691

## Steps 55 - 62 apply to XC90

- Remove the two centre floor hatches by lifting them slightly and then pulling them away from their mountings at the front edge. If the rear centre floor hatch is equipped with grocery bag holder on the underside then the floor hatch is secured with a belt on each short side of the storage box. These must be detached.
- Remove the storage box.



56

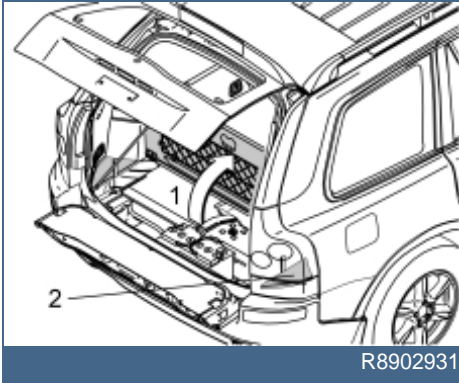

**Steps 55 - 62 apply to XC90**

**Applies to cars with three rows of seats and integrated carrier bag holder on the underside of the centre floor hatch**

- Fold up the centre rear floor hatch (1).
- Detach the two straps on the underlying panel. Lift up the rear edge of the panel, fold the floor hatch back and lift out the floor hatch with the panel.

**Applies to cars with three rows of seats without an integrated carrier bag holder**

- Lift up the centre rear floor hatch at the rear edge and lift it out.

**Applies to all models**

- Remove the right-hand side floor hatch (2).

57

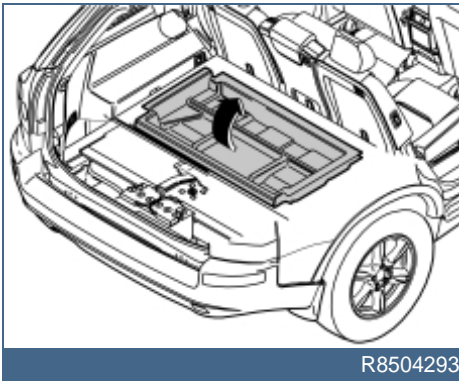

**Steps 55 - 62 apply to XC90**

**Applies to cars with two rows of seats**

- Remove the front storage box.

58

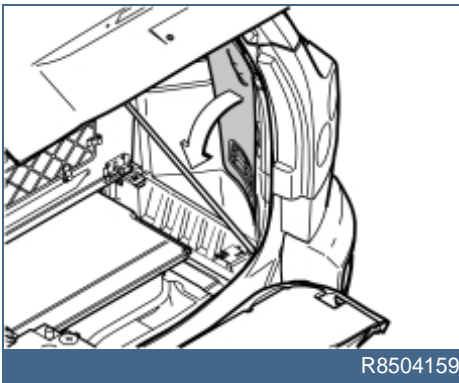

**Steps 55 - 62 apply to XC90**

- Remove the folding side panel from the right-hand side of the cargo compartment.

59

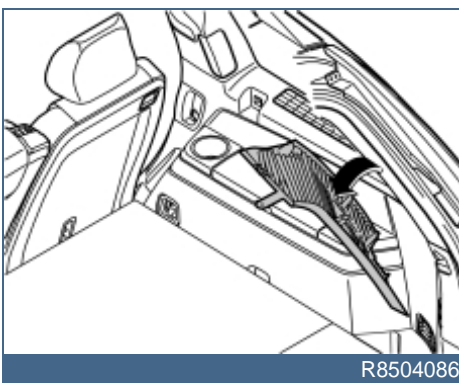

**Steps 55 - 62 apply to XC90**

- Carefully pull off the top edge of the right-hand D pillar panel. Continue down until the three clips have released.
- Remove the panel by pulling it straight up and unhook it from the side panel. If applicable, disconnect the connector for the D pillar loudspeaker.



60

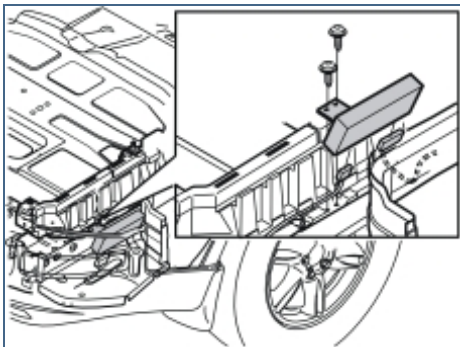

R3702881

Steps 55 - 62 apply to XC90

61

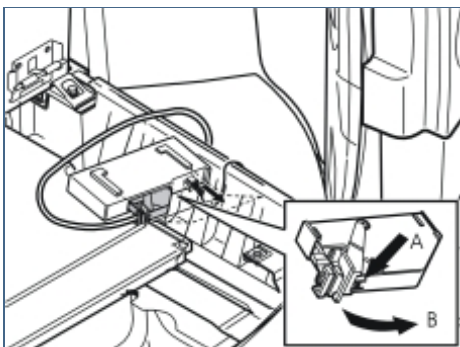

R3702909

Steps 55 - 62 apply to XC90

62

Steps 55 - 62 apply to XC90

- Carry out steps 42-54.